

SA - 111

AAA batteries supply : +5V / -5V output voltages

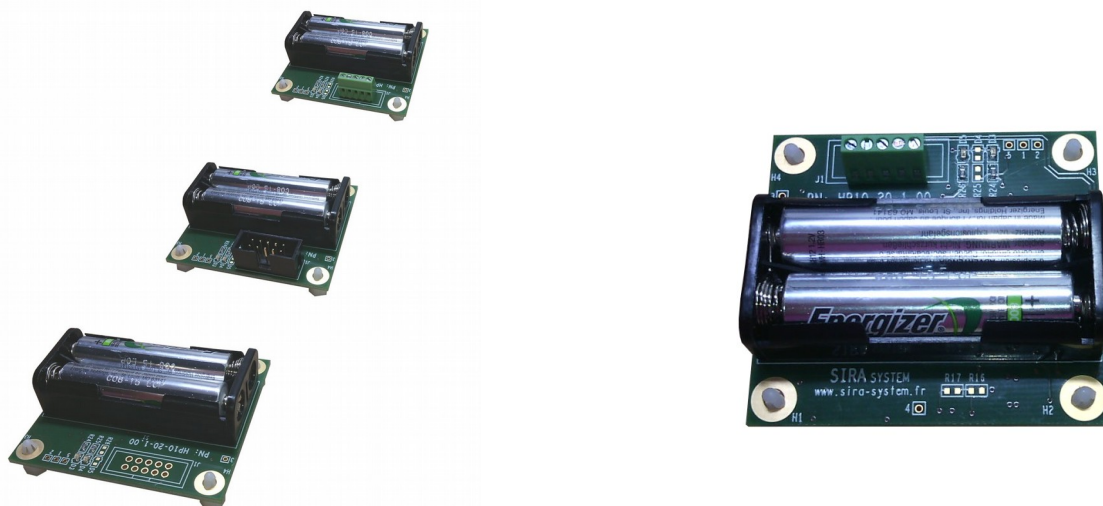

Description

The SA-111 module is a ready-to-use power supply that generates +5V and -5V regulated output voltages thanks to 2 AAA batteries.

Its outputs on HE10 connector, screw terminal or wire soldering allow great flexibility.

This power supply is designed to be quickly added to any mobile and portable equipment.

It is specifically developed for use with analog & digital boards using a dual symmetric supply.

The power can be controlled by a pulse (push-button type) or a stable voltage level (switch type)

A model is also available without control; the output voltages are present at the connection of the batteries.

General features

Dimensions	55mm x 50mm
Weight	30g
MTBF at 25°C	336.000 h
MTBF at 40°C	271.000 h

Batteries

Type	AAA / LR03
Number of elements	2
Minimum voltage	+2 V (+1 V per element)
Polarity inversion	Electronic protection

Power outputs

Load regulation (full load)	4 %
+5V output (I_{5V})	200mA max ⁽¹⁾
Efficiency	80 %
Tolerance (no load)	± 3 % (± 150mV)
-5V output (I_{-5V})	200mA max ⁽¹⁾
Efficiency	60 %
Tolerance (no load)	± 3 % (± 150mV)

⁽¹⁾ Maximum output current : $I_{5V} + I_{-5V} = 200mA$

Climatic conditions

Storage temperature	-20°C to +70°C
Operating temperature	-20°C to +50°C

Available references

The product reference is constructed as follows :

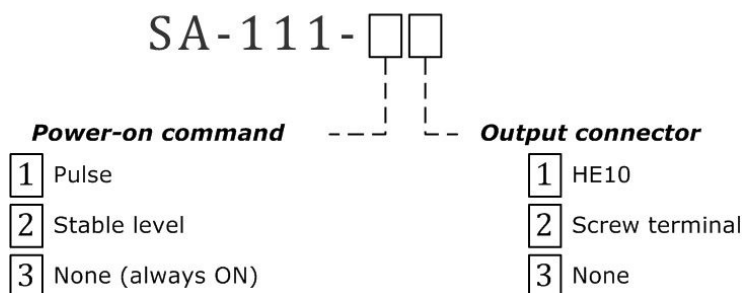

Available references are the following :

SA-111-11	SA-111-21	SA-111-31
SA-111-12	SA-111-22	SA-111-32
SA-111-13	SA-111-23	SA-111-33

Overview

The SA-111 board provides +5V and -5V regulated voltages. The DC / DC converters allow to overcome the voltage fluctuations of the battery linked to aging or to a significant current use.

The V_{BAT} output voltage provides permanently the batteries voltage once they are mounted on the board.

V_{ENA} is an input that control the power on / power off of the module. Various types of commands are detailed thereafter.

The user has access to 5 output signals on the card :

+5V	+5V regulated supply
-5V	-5V regulated supply
GND	Ground
V_{BAT}	Battery voltage
V_{ENA}	SA-111 Enable

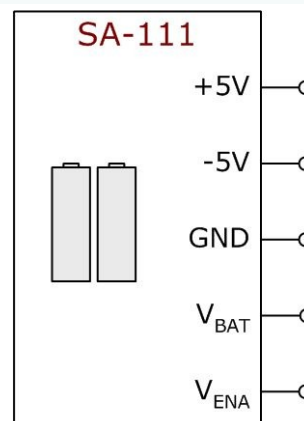

Maximum characteristics

V_{BAT_MIN} – Minimum voltage V_{BAT}	+2,0 V
<i>condition : $I_{5V} + I_{-5V} < 10mA$</i>	
V_{BAT_MAX} – Maximum voltage V_{BAT}	+3,3 V
V_{ENA_MIN} – Minimum voltage V_{ENA}	V_{BAT_MIN}
V_{ENA_MAX} – Maximum voltage V_{ENA}	V_{BAT_MAX}
I_{ENA_MAX} – Maximum input current	< 0,1mA
<i>condition : $V_{ENA} < V_{ENA_MAX}$</i>	
I_{MAX} – Maximum output current ($I_{5V} + I_{-5V}$)	200mA

Batteries

Maximum voltage	+3,3 V
	+1,65 V per element

Operating characteristics

Ripple

The ripple is given in the following table as a function of the load connected to the power supply.

The full load is done with :

- 100mA on the +5V output
- 100mA on the -5V output

For each power supply, the ripple is indicated by peak to peak voltage and RMS voltage

Load :	0 %	100 %
+5V	60 mV _{P-P}	40 mV _{P-P}
	12 mV _{RMS}	10 mV _{RMS}
-5V	50 mV _{P-P}	40 mV _{P-P}
	11 mV _{RMS}	9 mV _{RMS}

Conditions : $V_{BAT} = 2,8V$

Minimum load

To ensure optimum operation of the power-on of the card, a 10kΩ minimum load must be mounted on the + 5V (500uA current flow). This minimum load is easily reached when another board is powered.

The omission of this load (no load operation) causes no default, but the regulation of voltages may be longer to stabilize.

Load regulation

The quality of the regulation according to the connected load is given in the following table.

The deviation of the load regulation is observed as a percentage of the no-load voltage.

Maximum load for the +5V supply : 200mA

Maximum load for the -5V supply : 200mA

Load :	0 % to 100 %
+5V	< 1,5 %
-5V	< 2,5 %

By dividing the maximum load, ie 100mA on the +5V and 100mA on the -5V, we get:

on the +5V output, a maximum deviation of 2,5% with respect to the no-load regulation voltage.

on the -5V output, a maximum deviation of 4,0% from the no-load regulation voltage.

Connectors and card connection

HE10 or similar IDC connector.

References SA-111-x1

This 10-points connector is used with a 1,27mm pitch flat cable. The connector pitch is 2,54mm.

The male-female connector facilitates multiples connections / disconnections.

Signal	Pin
+5V output	1 et 2
Ground	3 et 4
-5V output	5 et 6
V _{BAT} output	7 et 8
V _{ENA} Enable input	9 et 10

Two LEDs are used to visualize the presence of the output voltages.

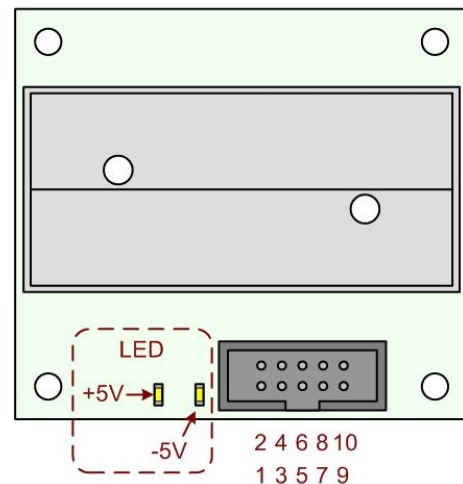
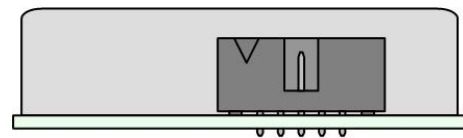

Screw terminal.

References SA-111-x2

This connector allows a quick connection by wires.

Signal	Pin
+5V output	1
Ground	2
-5V output	3
V _{BAT} output	4
V _{ENA} Enable input	5

Two LEDs are used to visualize the presence of the output voltages.

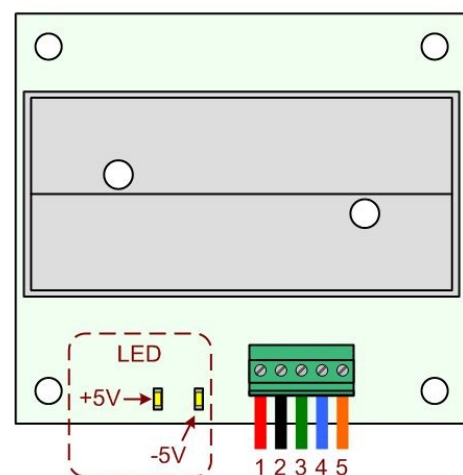
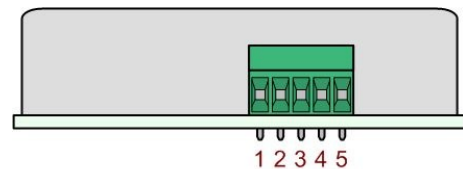

Bare outputs.

References SA-111-x3

This output allows the user to solder his own connector or directly bare wires .
The spacing between each hole is 2.54mm

Signal	Pin
+5V output	1 et 2
Ground	3 et 4
-5V output	5 et 6
V _{BAT} output	7 et 8
V _{ENA} Enable input	9 et 10

Signal outputs are doubled but only one connection to each of them is sufficient.

For example, use of pins 1, 3, 5, 7 and 9.

Two LEDs are used to visualize the presence of the output voltages.

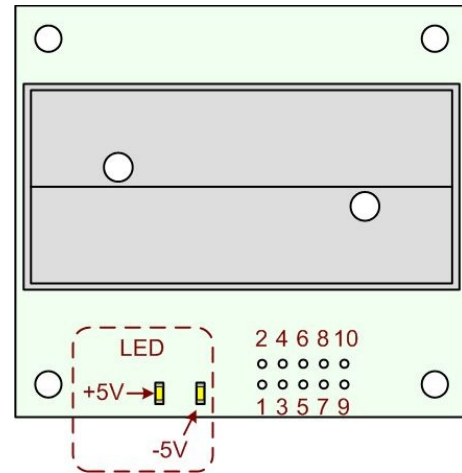

Power-on

Pulse command.

References SA-111-1x

This product reference includes the board steering with a pulse command such as a push-button.

The permanent voltage V_{BAT} must be connected to V_{ENA} to allow power output +5V and -5V (item 1). When V_{ENA} is released, the SA-111 card remains active.

Similarly, connecting again V_{BAT} to V_{ENA} causes the cut of the power supplies +5V and -5V (item 2).

A debouncing circuitry is mounted on the SA-111, which allows the direct plug of an external equipment such as a push button.

This pulse command may also be performed based on semiconductors.

The pulse width should be under 300ms.

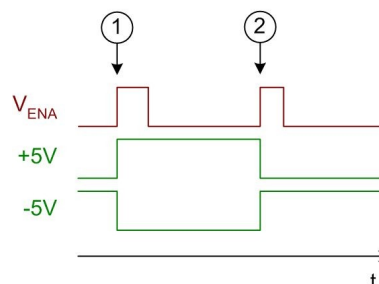
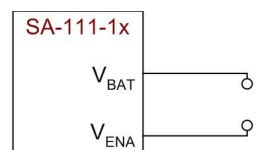

Level command.

References SA-111-2x

This board reference is controlled by imposing stable states on V_{ENA} .

The simplest control is the switch. A semiconductor-based control is also possible with respect to the input characteristics of V_{ENA} .

The permanent voltage V_{BAT} must be connected to V_{ENA} to allow power output +5V and -5V (item 1). V_{ENA} must be maintained during the operation of the SA-111.

The cut of the power supplies +5V and -5V (item 2) is caused by the opening of the switch.

A debouncing circuitry is mounted on the SA-111, which allows the direct plug of an external equipment such as a switch.

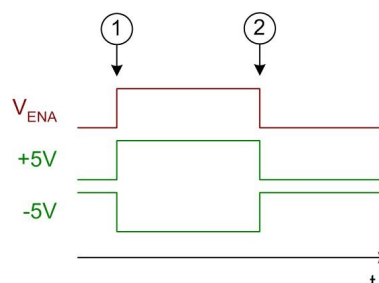
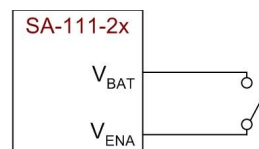

No command.

References SA-111-3x

The power supplies +5V and -5V are set consistently since the connection of the batteries.

Dimensions

All dimensions in mm.

Top view :

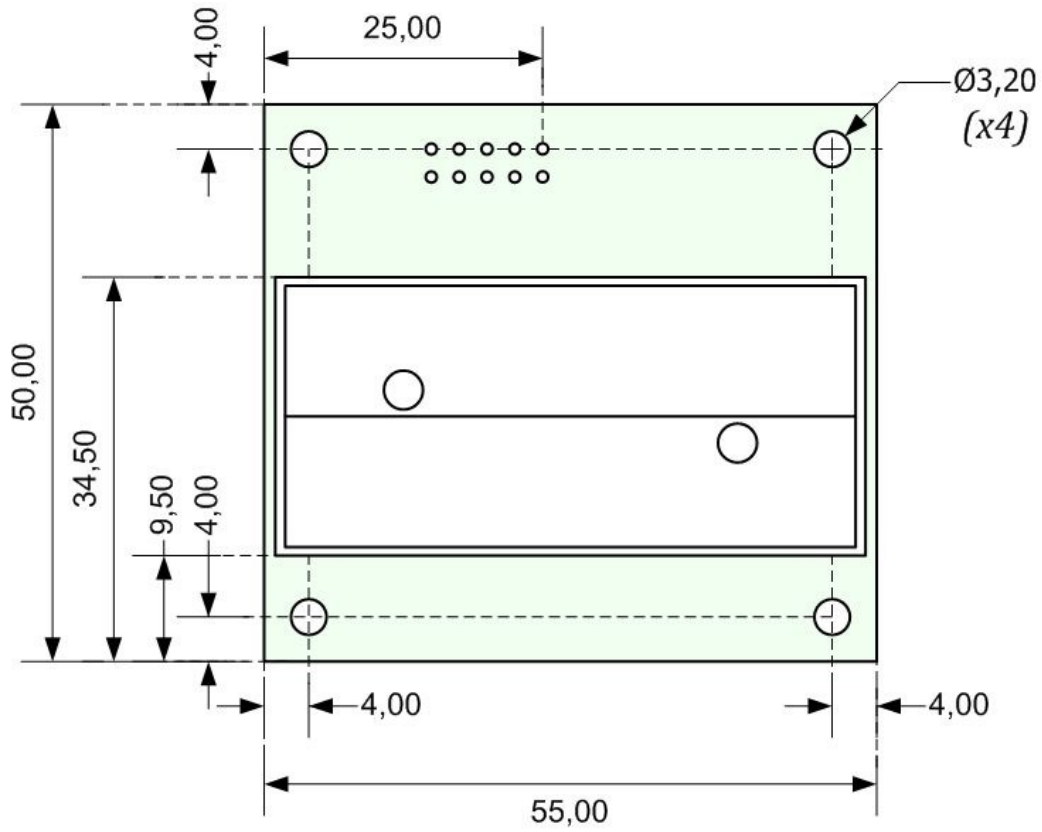

Side view :

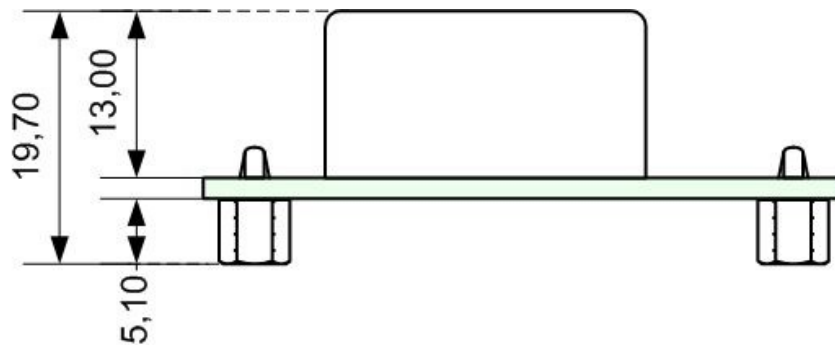

The default mounted feet can be easily removed.

If necessary, the user can quickly assemble its application-specific feet.

